

www.vskom.de

OpenRISC Alena Hardware Manual

Edition: June 2013



Vision Systems GmbH

Tel: +49 40 528 401 0

Fax: +49 40 528 401 99

Web: www.visionsystems.de

Support: faq.visionsystems.de

The software described in this manual is furnished under a license agreement and may be used only in accordance with the terms of that agreement.

Copyright Notice

Copyright © 2009-2013 Vision Systems. All rights reserved. Reproduction without permission is prohibited.

Trademarks

VScom is a registered trademark of Vision Systems GmbH. All other trademarks and brands are property of their rightful owners.

Disclaimer

Vision Systems reserves the right to make changes and improvements to its product without providing notice.

Vision Systems provides this document “as is”, without warranty of any kind, either expressed or implied, including, but not limited to, its particular purpose. Vision Systems reserves the right to make improvements and/or changes to this manual, or to the products and/or the programs described in this manual, at any time.

Information provided in this manual is intended to be accurate and reliable. However, Vision Systems assumes no responsibility for its use, or for any infringements on the rights of third parties that may result from its use.

This product might include unintentional technical or typographical errors. Changes are periodically made to the information herein to correct such errors, and these changes are incorporated into new editions of the publication.

Contents

1	Overview	5
1.1	Product Features	5
1.2	Hardware Specifications	6
1.2.1	System	6
1.2.2	Serial Ports	6
1.2.3	Digital I/O	7
2	Position of Connectors and Functions	8
2.1	LEDs	9
2.2	Reset Button	9
3	Dimensions	10
4	Connectors	11
4.1	Power	11
4.2	Grounding	11
4.3	LAN	11
4.4	Serial	11
4.5	CAN	11
4.6	Console Port	12
4.7	CF-Slot	12
4.8	microSD-Slot	12
4.9	USB	12
4.10	Digital I/O	12
4.11	I ² C	13
5	Internal Components	14
5.1	Serial Port Jumper Block	14
5.1.1	Termination Resistors	14
5.1.2	BIAS Function	14
5.2	Internal Flash Write Protection	14
5.3	UMTS/LTE (3G/4G)	15
5.4	SIM Card	15
5.5	Battery	15
6	Product Support Information	16

List of Figures

1	Appearance	8
2	Case	10
3	Terminal Resistors	14
4	WP Jumper	15

List of Tables

1 Product Hardware Specifications 6
2 Serial Interface Specifications 7
3 LED Indicators 9
4 DSUB Pinout 12
5 RS422/485 Jumper Configuration 14

1 Overview

The OpenRISC Alena is an ARM9-based RISC industrial embedded computer. The great variety of interfaces like LAN, CAN, CF, USB, I²C, serial interface and digital I/O makes it easy to connect various industrial devices to the OpenRISC Alena.

Compact dimensions and DIN Rail mounting capability make the OpenRISC Alena to a space saving and flexible mounting industrial computer. It is feasible to be installed even in space limited environments.

Due to RISC based architecture the OpenRISC Alena has very small power consumption (6,5 Watt), so fanless heat dissipation is possible. Working in an extended temperature range from -10°C up to 65°C the OpenRISC Alena can be used under harsh industrial conditions. Therefore the OpenRISC Alena is downright designed for industrial automation.

1.1 Product Features

- ARM9 32-bit RISC CPU, 166MHz
- 64MB SDRAM on board
- 4MB Flash on board
- 2 x RS232/RS422/RS485 serial ports
- 2 x RS232 serial ports
- 1 x CAN port
- 4 independent digital I/O channels
- 2 optically isolated digital input channels
- 2 relays
- 1 x CF-Slot in True IDE mode (accepts MicroDrives)
- 1 x microSD-Slot
- 2 x USB 2.0 as Host
- MiniPCI-slot for expansion with WLAN, GPS etc.
- 2 x Ethernet interfaces for redundant networking or routing functions
- I²C bus with max. 330kHz clock
- RTC
- Ready-to-Run Debian Linux for ARM operating system
- DIN-Rail and wall-mount installation
- Robust, fanless design
- Wide temperature range -10 to 65°C
- Buzzer, Watch Dog Timer

1.2 Hardware Specifications

1.2.1 System

	OpenRISC Alekto
CPU	ARM9 32-bit RISC CPU, 166MHz
RAM	64MB SDRAM
Flash	4MB
CF-Slot	True IDE mode (accepts MicroDrives)
microSD-Slot	1 x internal
USB	2 x 2.0 as Host
LAN	10baseT/100baseTX Autodetect and Auto-MDI(X)
Serial Ports	2 x RS232/RS422/RS485 up to 3.6Mbps 2 x RS232 up to 921,6Kbps
CAN ports	1 x SJA1000 up to 1Mbps
Digital I/O	4 x input/output signals (32 mA max.) 2 x optically isolated input channels 2 x relays
Console Port	RS232, up to 115200bps
I ² C	max. 330kHz
RTC	yes
Buzzer	yes
Watch Dog Timer	yes
MiniPCI-Slot	yes
Reset Button	HW Reset, long hold to access BIOS via Telnet
Power Input	9-30V DC
Power Consumption	max. 1.5A @ 12V
Dimensions (W x L x H)	157 x 106 x 53 mm 157 x 112 x 53 mm with DB9 connector

Table 1: Product Hardware Specifications

1.2.2 Serial Ports

Two serial ports are provided in RS232/422/485 modes that can be switched by software. For the detailed information about the supported modes refer to the Table 2.

	RS232	RS422	RS485
Modes	full duplex	full duplex	2-wire: half duplex, with echo 2-wire: half duplex, without echo 4-wire: full duplex
Signals	TxD, RxD, RTS, CTS, DTR, DSR, DCD, RI, GND	Tx+/-, Rx+/-, GND	2-wire: Data+/-, GND 4-wire: Tx+/-, Rx+/-, GND
Data Direction Control			by ART (Automatic Receive Transmit control) or by RTS
Speed	up to 921.6 Kbps	up to 3.6 Mbps	up to 3.6 Mbps

Table 2: Serial Interface Specifications

1.2.3 Digital I/O

Four input/output signals at TTL level are provided. The signal direction is individually configurable. Each signal carries up to 32mA in both directions. For input mode the change of at least one input signal generates an interrupt.

2 Position of Connectors and Functions

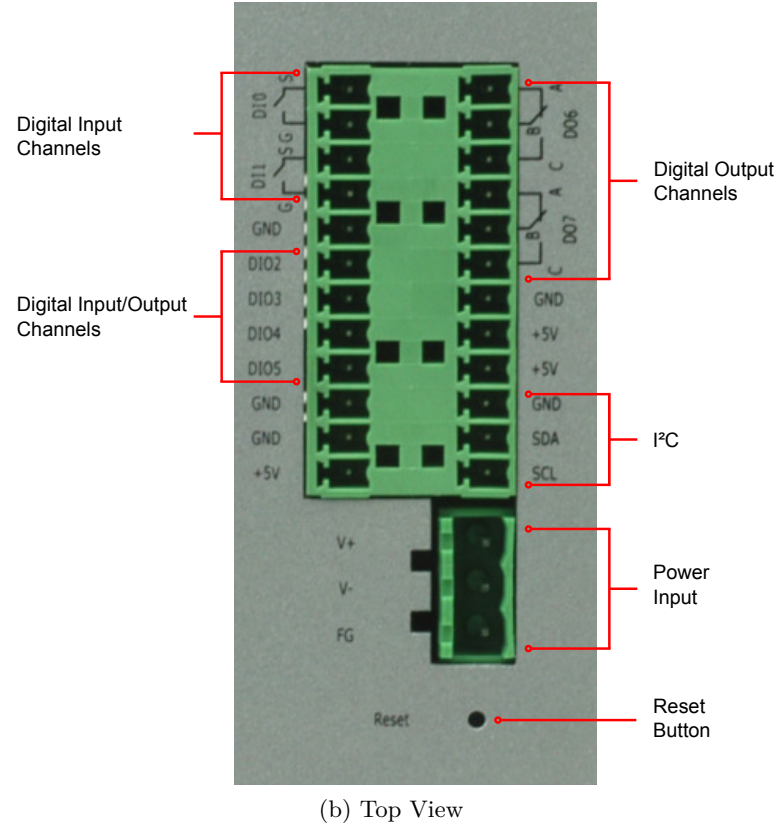
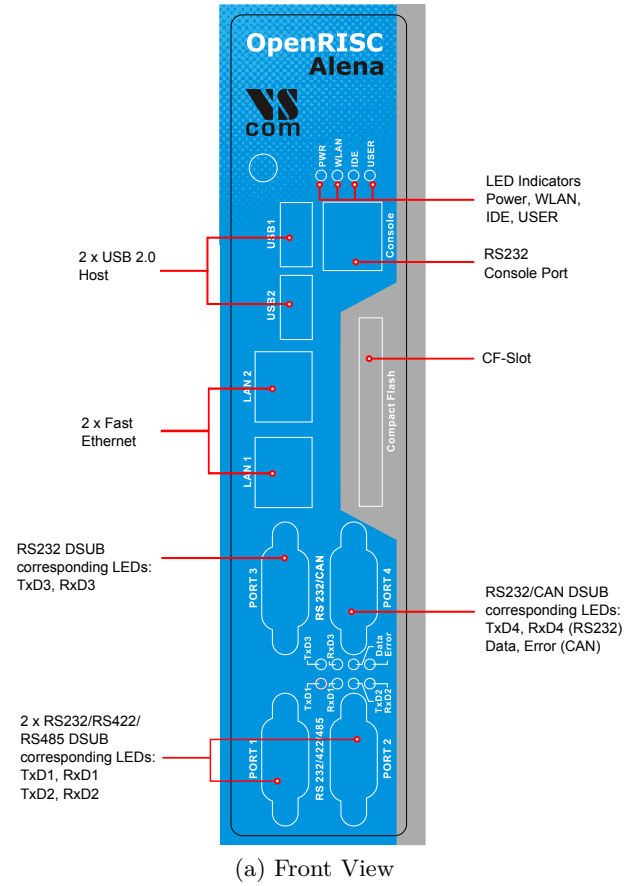

Figure 1: Appearance

2.1 LEDs

Name	Color	Description
POWER	Red	Power is on
WLAN	Blue	WLAN card has a connection to AP
IDE	Yellow	CF is in use
USER	Green	Customizable
LAN1, LAN2	Yellow Green	Ethernet connection established, blinks with traffic On if 100 Mbps link
TxD1, TxD2, TxD3	Green	Transmit traffic
RxD1, RxD2, RxD3	Yellow	Receive traffic
Data	Green	CAN traffic (shared with TxD4)
Error	Yellow	CAN errors (shared with RxD4)

Table 3: LED Indicators

2.2 Reset Button

With Reset button you can restart the OpenRISC Alena without removing the power. It can be also used to get in BIOS via Telnet (see Table 1). For further information refer to the “OpenRISC User Manual” section “BIOS”. The Reset button should be used only in situations, where reboot command is not available, to avoid filesystem integrity errors.

3 Dimensions

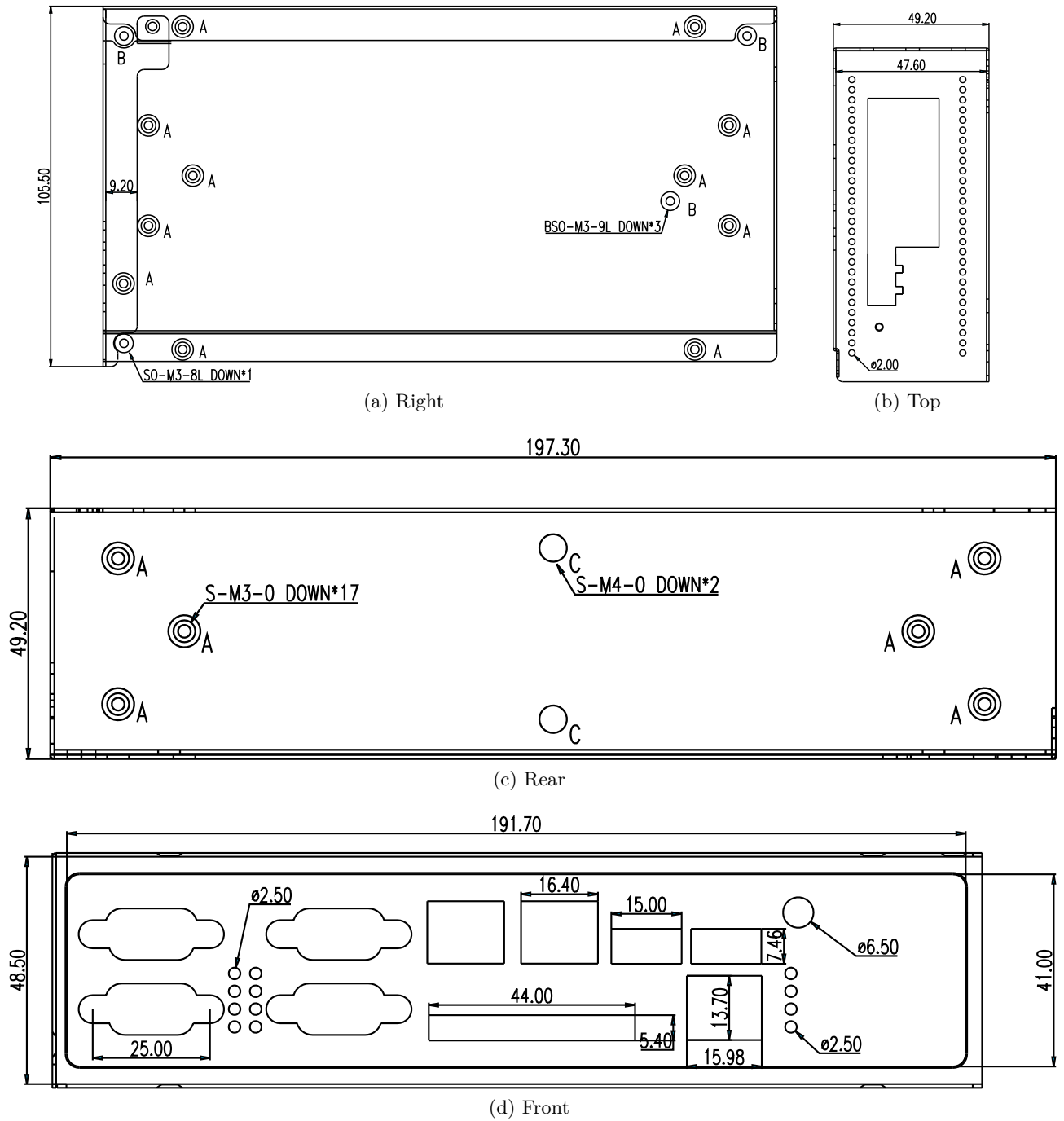

Figure 2: Case

4 Connectors

4.1 Power

The OpenRISC Alena device is powered by a single power supply in a wide range from 9V DC to 30V DC. A suitable power supply adapter is part of the packaging list. Connect the cable to the power jack at the top side of OpenRISC Alena, and put the adapter into the socket. The Power LED (red) on OpenRISC Alena will light. You can connect a power supply of your choice, providing the technical requirements are met.

Warning: disconnect the OpenRISC Alena before performing installation or wiring. The wire size must follow the maximum current specifications. The maximum possible current in the power wires as well as in the common wires must be taken under consideration. If the current rises above the maximum ratings, the wiring can overheat, causing serious damage to your equipment. When powered, the OpenRISC Alena's internal components generate heat, and consequently the outer case may feel warm to the touch.

4.2 Grounding

Grounding and wire routing help limit the effects of noise due to electromagnetic interference (EMI). Run the ground connection from the ground screw to the grounding surface prior to connecting devices.

4.3 LAN

The connectors for Ethernet are the usual RJ45. Simply connect them to your switch or hub. When the connect is done the Link LED on RJ45 (yellow) will light. When data traffic occurs on the network, this LED will blink. It depends on your network whether a 100Mbit or a 10Mbit connect will be established. A 100Mbit net causes the Speed LED on RJ45 (green) to light, otherwise it will remain dark. Both Ethernet interfaces support Auto-MDI(X) feature.

4.4 Serial

The OpenRISC Alena has four DSUB 9 male connectors. All three modes of operating RS232, RS422 or RS485 are entirely configured by software. For the pinout refer to the Table 4.

Please note the function of the GND signal in RS422 and RS485 modes: this signal must also be connected between the serial devices. So in reality a 2-wire and a 4-wire connection need 3 wire and 5 wire respectively. With the exception of very special configurations, a serial connection in RS422/RS485 mode without GND connection violates the specifications for RS422 and RS485 standards.

4.5 CAN

The OpenRISC Alena provides one CAN interface with a DSUB 9 male connector (PORT4) that is shared with the fourth serial port (see Table 4 for pinout). The physical drivers will be switched between CAN and RS232 per software.

Pin	RS232	RS422	RS485 2wire	CAN
1	DCD	Tx- (A)	Data- (A)	
2	RxD	Tx+ (B)	Data+ (B)	CANL
3	TxD	Rx+ (B)		GND
4	DTR	Rx- (A)		
5	GND	GND	GND	
6	DSR			
7	RTS			CANH
8	CTS			
9	RI			

Table 4: DSUB Pinout

4.6 Console Port

The console port (RS232) has an RJ45 connector. An adapter cable to DB9 male is provided. The pinout of the DB9 male connector is the same as PORT1-4 in RS232 mode, without signal RI.

4.7 CF-Slot

The CF-Slot supports True IDE mode for storage expansion. The memory size of the CF-Card is not limited. For use with the prepared Debian Linux image it is recommended to use at least 1GB CompactFlash. MicroDrives can be also used.

4.8 microSD-Slot

The OpenRISC Alena provides one microSD-Slot inside the case so it is not accessible from outside. This slot can be used in the same way as CF-Slot to store the system or it can be used as extra storage device.

4.9 USB

The OpenRISC Alena provides two USB 2.0 Host interfaces. They can be used for Mass Storage Devices, like Flash- or Hard Drive, Bluetooth and WLAN adapters etc.

4.10 Digital I/O

The OpenRISC Alena provides 4 digital input/output channels, 2 optically isolated digital input channels and 2 relays. The data direction for each I/O channel can be independently set to input or output. An interrupt for an input channel can also be independently enabled to detect signal level changes. The physical driver operates with 32mA for both high and low level.

4.11 I²C

The I²C interface operates at the maximum frequency of 330 KHz. The connector for I²C is located on the terminal digital I/O block and has three pins: SCL, SDA and GND. When required the I²C device can be powered with the VCC output of the digital I/O terminal block.

5 Internal Components

5.1 Serial Port Jumper Block

In typical RS422 and RS485 installations certain electric conditions have to be configured. Simply connecting cables is not enough to fulfill the specifications of RS422 and RS485.

For ease of installations the OpenRISC Alena provides these functions for often used parameters. They are activated by placing certain jumpers (see Table 5), internal of the OpenRISC Alena. There is one block of jumpers (see Figure 3) for each serial port (JP5 for Port 1 and JP6 for Port 2). Place a connection cap to activate the function.

Pins	Function of Signals
1-2	Place 120Ω to terminate Tx+/- (Data+/- in RS485 2-wire)
3-4	Add BIASing function to Tx+/-
5-6	(mostly required for RS485 2-wire modes)
7-8	Place 120Ω to terminate Rx+/-
9-10	Add BIASing function to Rx+/-
11-12	Add BIASing function to Rx+/-

Table 5: RS422/485 Jumper Configuration

Warning: All jumpers are unconnected by default. This is important for use in RS232 mode. Never close any jumper, otherwise communication errors or damage of devices is possible.

5.1.1 Termination Resistors

The use of long communication lines in RS422 and RS485 mode require the installation of termination resistors. These must match the impedance of the cable. Typical cables in Twisted-Pair configuration have an impedance around 120Ω . In RS422 this resistor has to be placed at the far end from the sender, in RS485 the typical configuration requires one resistor at each end of the cable.

5.1.2 BIAS Function

RS485 requires a BIAS option for the communication lines. This will guarantee stable electrical levels on the cables, even at times when no station is transmitting data. Without BIAS there will be noise on the cable, and sometimes receivers can not detect the first characters of a beginning communication.



Figure 3: Terminal Resistors

5.2 Internal Flash Write Protection

JP1 (see Figure 4) on the CPU board is responsible for protecting first flash partition where RedBoot is installed. When JP1 is closed the RedBoot partition is protected, when opened the partition is writable. Always keep the JP1 closed unless you want to change this partition.

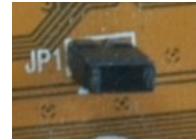

Figure 4: WP Jumper

5.3 UMTS/LTE (3G/4G)

There is one expansion slot to hold a Mini PCI Express Card, in long size format. This slot supports the data signals for USB 2.0, so the selected card must operate on USB. PCI Express is not available. Typical cards placed into this expansion slot are Wireless communication cards.

5.4 SIM Card

If the miniPCIE card is for mobile communication by GSM/GPRS/EDGE/UMTS/LTE, it will use a SIM card for the account data to access the providers network. This SIM card shall be inserted into the special slot, which is connected to the miniPCIE slot. The slot for SIM cards is accessible on the front side, i.e. when the case is closed. Note: There are add-on cards with an integrated SIM slot. Depending on the model both slots are functional, i.e. a SIM card may be placed either in the external or the integrated slot.

5.5 Battery

There is a clip to hold a CR2032 type Lithium battery. This battery provides the backup power for the Real Time Clock. When a replacement of the battery is required, convenient access is by removing the front-left cover. But the location at the rear side also allows access by removing the back side of the case.

6 Product Support Information

The following services are provided on www.vscom.de and www.visionsystems.de for the customers to support our products:

- driver updates
- product information
- user's manual updates

For special technical support issues please use our FAQ system faq.visionsystems.de.